



# Building Guide

International Code Council

## Single Family Residential Patio Covers & Carports

### How to Use this Guide

Provide two sets of plans, drawn to scale and complete the following (*hint: use graph paper with 1/4" squares. Example: 1/4" = 1'*): Check with your jurisdiction for additional requirements.

**1 Complete this Building Guide** by filling in the blanks on page two, and indicating which construction details will be used.

**2 Provide 2 Plot Plans** (site plan) showing dimensions of your project or addition and its relationship to existing buildings or structures on the property and the distance to existing property lines drawn to scale. See Page 2

### 3 Fill out a building permit application.

The majority of permit applications are processed with little delay. The submitted documents will help determine if the project is in compliance with building safety codes, zoning ordinances and other applicable laws.

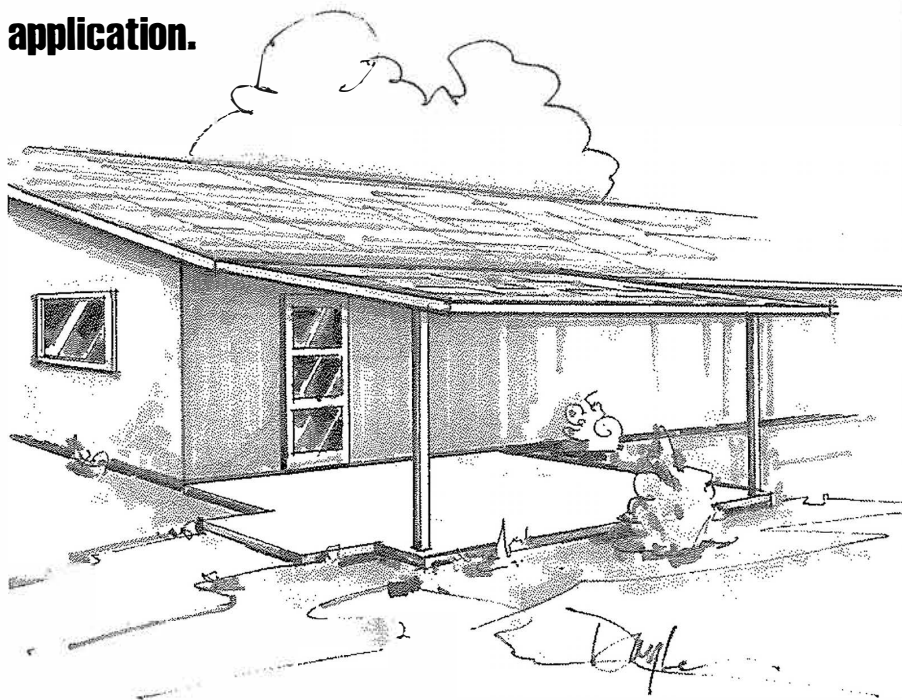

This handout was developed by the Colorado Chapter of the International Code Council as a basic plan submittal under the 2012 International Residential Code. It is not intended to cover all circumstances. Check with your Department of Building Safety for additional requirements.



# Single Family Residential Patio Covers & Carports

## Site Plan Example

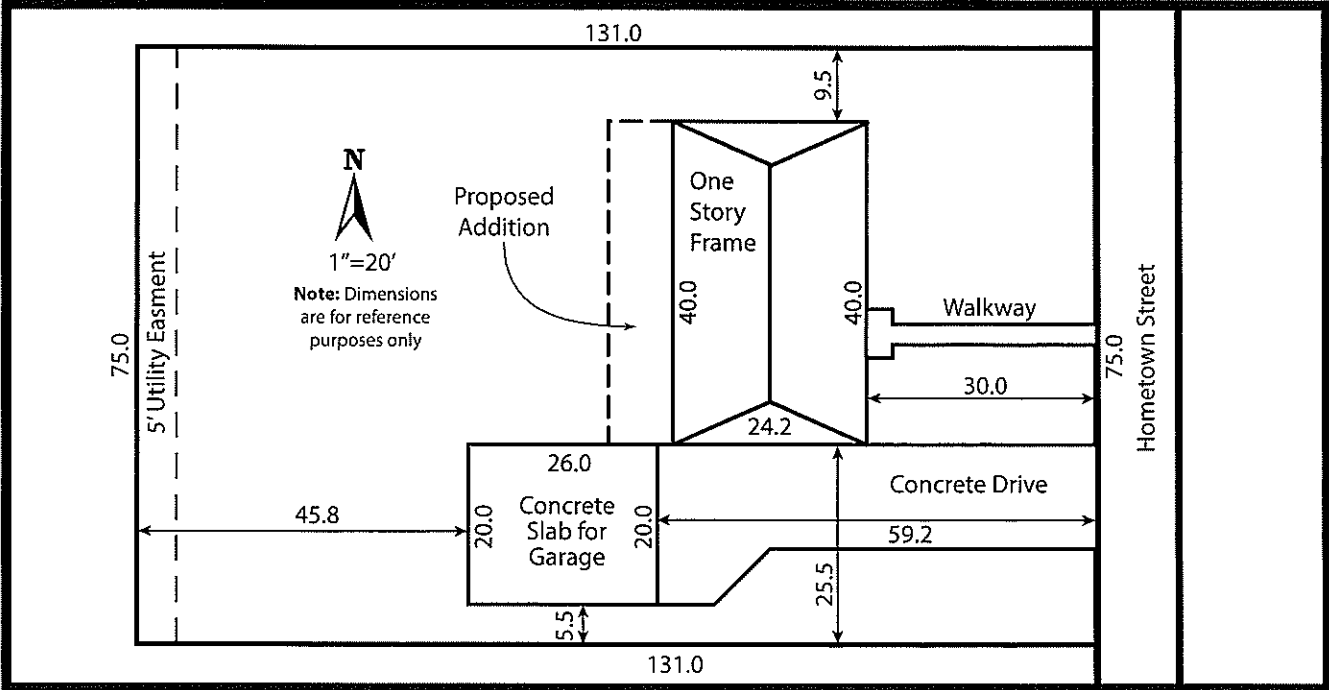

This handout was developed by the Colorado Chapter of the International Code Council as a basic plan submittal under the 2012 International Residential Code. It is not intended to cover all circumstances. Check with your Department of Building Safety for additional requirements.



# Single Family Residential Patio Covers & Carports

## Directions

Address: \_\_\_\_\_

1. Fill in the blanks with dimensions and materials which will be used to build the structure. Please print legibly.
2. Indicate in the check boxes which details from page 4 will be used. Please note if any of the sides of your carport addition are closer than 5'-0" to the property line, that side of the carport must be enclosed with a solid 1 hour fire rated wall as shown in Alternate Details B and C. You must however, keep at least two sides of the carport open to conform to the building code requirements. Zoning approval is required.
3. Roofing to be installed per manufacturer's instructions, including low slope application and required inspections made.

Roof covering \_\_\_\_\_  
*(example: Class A 3 tab shingles)*

Underlayment \_\_\_\_\_  
*(example: 15# felt with 19" laps)*

Size and Amount of Lags  
*(example: Two 1/2"x 4 1/2" lags @ 16" O.C.)*

Sheathing \_\_\_\_\_  
*(example: 1/2" exterior plywood)*

12 pitch | \_\_\_\_\_

2x \_\_\_\_\_ rafters spaced \_\_\_\_\_ " O.C.  
*(example: 2 x 8 rafters spaced 24" O.C.)*

## Patio Section

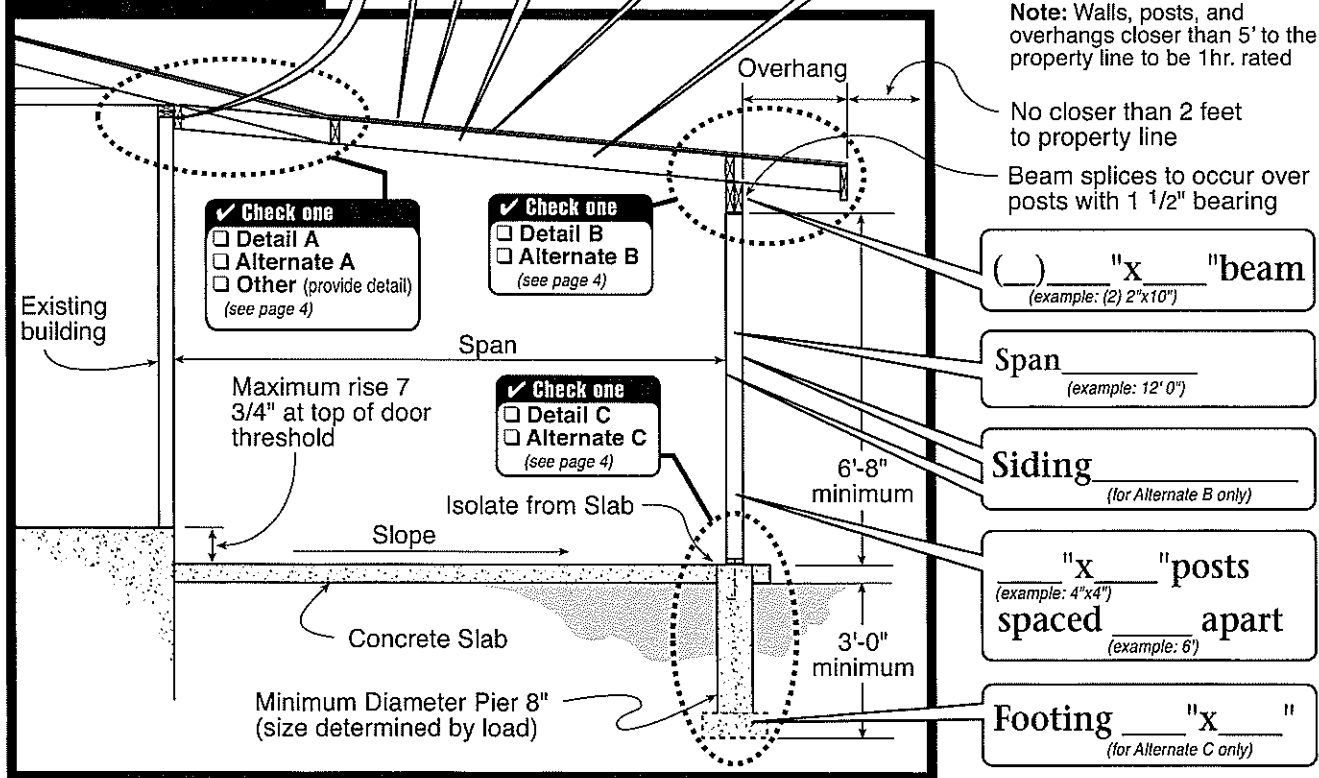

Note: Walls, posts, and overhangs closer than 5' to the property line to be 1hr. rated

No closer than 2 feet to property line

Beam splices to occur over posts with 1 1/2" bearing

( ) "x" beam  
*(example: (2) 2"x10")*

Span \_\_\_\_\_  
*(example: 12' 0")*

Siding \_\_\_\_\_  
*(for Alternate B only)*

"x" posts spaced \_\_\_\_\_ apart  
*(example: 4"x4") (example: 6')*

Footing \_\_\_\_\_ "x" \_\_\_\_\_  
*(for Alternate C only)*

This handout was developed by the Colorado Chapter of the International Code Council as a basic plan submittal under the 2012 International Residential Code. It is not intended to cover all circumstances. Check with your Department of Building Safety for additional requirements.

Permit #: \_\_\_\_\_



# Single Family Residential Patio Covers & Carports

## Detail A

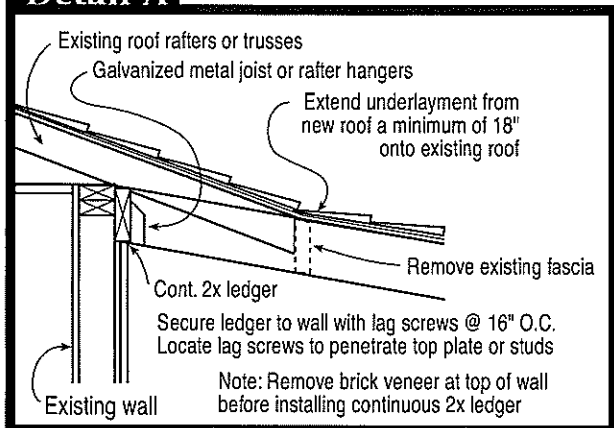

## Alternate Detail A

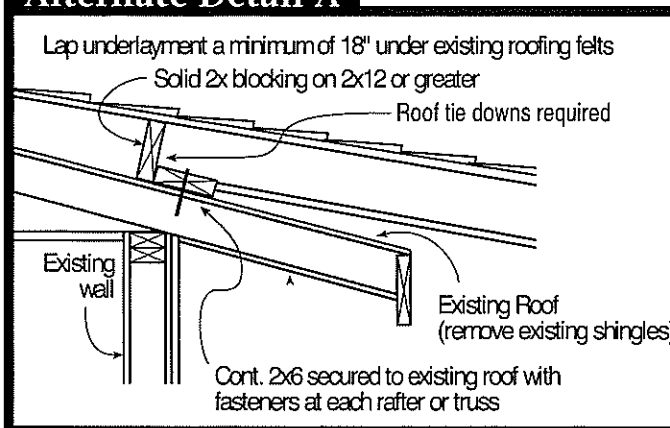

## Detail B

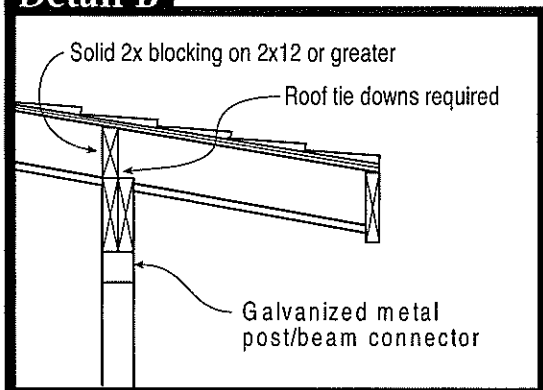

## Alternate Detail B - 1 Hour Wall

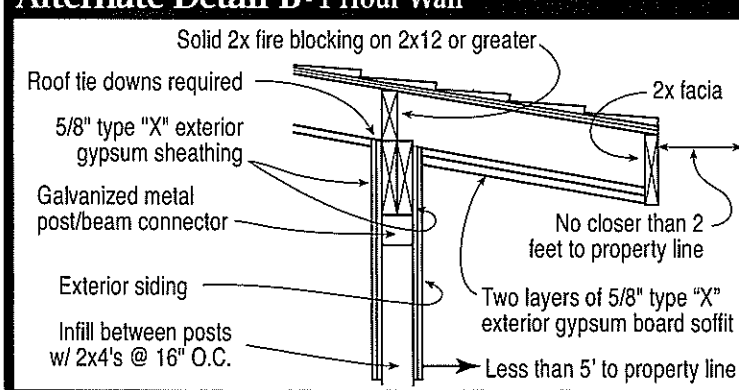

## Detail C

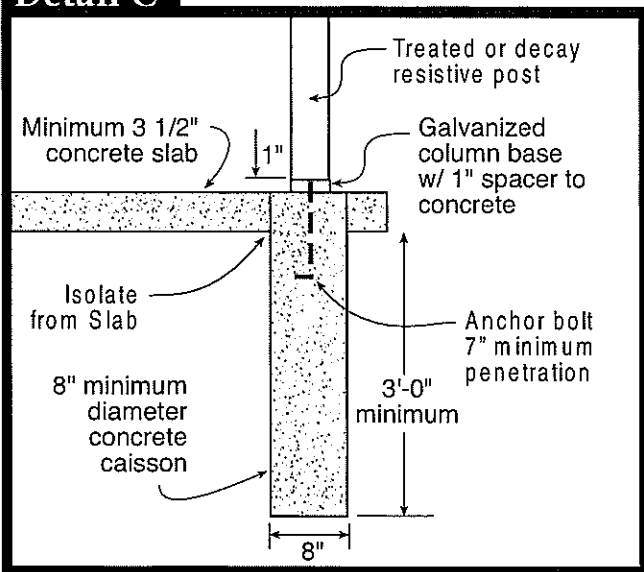

## Alternate Detail C - 1 Hour Wall

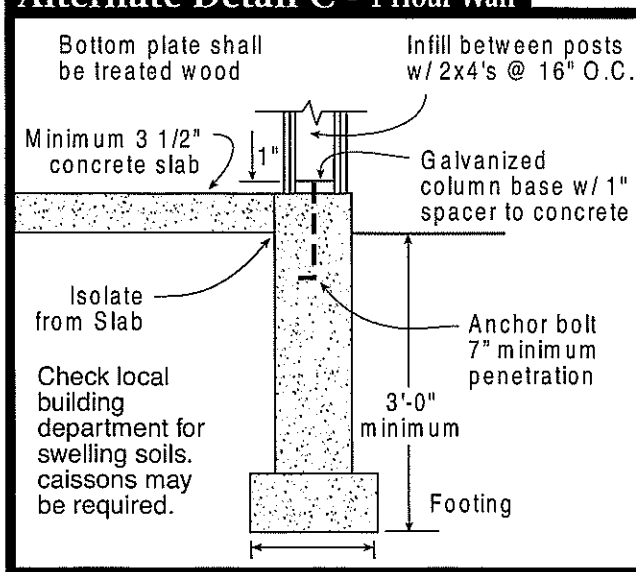

This handout was developed by the Colorado Chapter of the International Code Council as a basic plan submittal under the 2012 International Residential Code. It is not intended to cover all circumstances. Check with your Department of Building Safety for additional requirements.

